



---

**KRAMER ELECTRONICS, Ltd.**

# **USER MANUAL**

**VGA/XGA Switchers**

**Models: VP-31, VP-32xl, VP-61RS**

**IMPORTANT: Before proceeding, please read paragraph entitled  
"Unpacking and Contents"**

## Table Of Contents

Section	Name	Page
1	INTRODUCTION	1
1.1	A Word on VGA/XGA/Audio Switchers	1
1.2	Handling Graphics signals	1
1.3	Factors Affecting Quality of Results	2
2	SPECIFICATIONS	3
3	HOW DO I GET STARTED?	4
4	UNPACKING AND CONTENTS	4
4.1	Optional Accessories	4
5	VGA/XGA/AUDIO SWITCHERS	6
5.1	Getting To Know Your VP-31 Switcher	6
5.2	Getting To Know Your VP-32xl Switcher	7
5.3	Getting To Know Your VP-61RS Switcher	8
6	INSTALLATION	9
6.1	Rack Mounting	9
7	CONNECTING TO VGA/XGA DEVICES	9
8	CONNECTING TO AUDIO DEVICES	9
9	USING THE SWITCHERS	9
9.1	Powering On the Switcher	9
9.2	Selecting an Input on the Switchers	9
9.3	Controlling the VP-32xl	9
9.4	Controlling the VP-61RS	10
9.4.1	The VS-2000 System	10
9.4.2	DIP Switches	11
9.4.3	The "Reply" Option	12
9.5	VGA/XGA Switching	12
10	CONNECTING TO A PC (VP-61RS only)	13
10.1	PC Control Software	14
10.1.1	Installation	14
10.1.2	Software Controls	14
10.1.3	Using the PC Control Software	15
11	TAKING CARE OF YOUR SWITCHER	16
12	TROUBLESHOOTING	17
12.1	Power And Indicators	17
12.2	Audio Signal (VP-32xl only)	18
12.3	Video Signal	18
12.4	Control (VP-61RS only)	19
13	PROTOCOL USED FOR THE VP-61RS COMMUNICATION	20
13.1	Detailed Description	20

## List Of Illustrations

Figure	Name	Page
1	VP-31 Front/Rear Panel Features	6
2	VP-32xl Front/Rear Panel Features	7
3	VP-61RS Front/Rear Panel Features	8
4	VP-32xl Remote Connector Location and Pinout	10
5	Typical VS-2000 System Setup	11
6	Typical VGA/XGA Switching	13
7	RS-232 Control Connector Wiring	13
8	Connecting Multi-Machines	13
9	VP-32xl Fuse Location	18

## List Of Tables

Table	Name	Page
1	VP-31 Front/Rear Panel Features	6
2	VP-32xl Front/Rear Panel Features	7
3	VP-61RS Front/Rear Panel Features	8
4	DIP Switch Settings	12

## 1 INTRODUCTION

Congratulations on your purchase of this Kramer switcher. Since 1981 Kramer has been dedicated to the development and manufacture of high quality video/audio equipment. The Kramer line has become an integral part of many of the best production and presentation facilities around the world. In recent years, Kramer has redesigned and upgraded most of the line, making the best even better. Kramer's line of professional video/audio electronics is one of the most versatile and complete available, and is a true leader in terms of quality, workmanship, price/performance ratio and innovation. In addition to the Kramer line of high quality switchers, such as the one you have just purchased, Kramer also offers a full line of high quality distribution amplifiers, processors, interfaces, controllers and computer-related products.

This manual includes configuration, operation and option information for the following products from the Kramer VP line of switchers. All these VP switchers are similar in operation and features.

- **VP-31 - 3x1 VGA/XGA Switcher**
- **VP-32x1 - 3x1 VGA/XGA/Audio Stereo Switcher**
- **VP-61RS - 6x1 VGA/XGA Switcher**

### 1.1 A Word on VGA/XGA/Audio Switchers

VGA/XGA/Audio switchers route signals to one or more selected users. Generally, switchers vary in the number of inputs, looping capability, programming capability, number of outputs, operating format, bandwidth and input/output coupling. VGA/XGA/Audio switchers are used to select which source is to be switched to which acceptor for recording or monitoring, with no discernible signal degradation. Often, a signal processor is inserted between the source and the VGA/XGA/Audio switcher for correction and fine-tuning of the source signal before routing. The front panels of these Kramer switchers are designed to be simple to operate. Some of the switchers are RS232 controlled for remote PC operation. The machines described in this manual switch one of several PC's to a monitor. The machines excel in high source isolation for minimal crosstalk and very large bandwidth.

### 1.2 Handling Graphics signals

A computer generated graphics signal is usually composed of 5 signals: Red, Green, Blue - which are analog level signals - and two TTL (logic) level signals - Horizontal Sync and Vertical Sync. (Digital graphics cards and monitors use a different signal format, and will not be discussed here.)

Computer graphics resolution is measured in pixels and in signal bandwidth. The more pixels (picture elements) on the screen, the more the image is detailed. VGA, S-VGA, XGA, S-XGA and U-XGA are terms that describe graphics resolution and color depth. Color depth represents the maximum number of simultaneously displayed colors on the screen and is measured in bits. 24 and 32-36 bits of color depth represent millions to billions of color shades available on the screen at any given moment. It should be born in mind though that the human eye can resolve only a few thousands colors! The more the image is detailed (higher resolution) and the higher the color depth, the more real the image will look. The highest resolution of standard VGA was 640x480 pixels with 4 bits of color (16 colors). Standard VGA was able to use more colors (256) but at a lower resolution- around 320x200 pixels, which was very crude. Common resolutions used nowadays for computer graphics vary from 1024x768 up to 2000x1600 pixels with "high color" - 16 bits of color - representing 64,000 different colors, up to "true color" - 24 bits or more, representing from 16.7 million colors up to several billion. Displaying such a detailed and colorful image on the screen needs enormous graphics memory per frame, as well as very high speeds for "writing" so many pixels on the screen in real time. The amplifiers that carry those signals should be able to handle those speeds and signal bandwidth.

Standard VGA, at 640x480 resolution, required amplifiers with only 20-30MHz bandwidth. At 1600x1200 or even at 1280x1024 (S-XGA), such amplifiers will fail completely. In order to faithfully amplify and transmit modern high-resolution graphics, amplifiers with bandwidths of 300 MHz and more are needed. Those amplifiers, besides the enormous bandwidth they must handle, need to be linear, to have very low distortion and to be stable. Stability of an amplifier is its ability to avoid bursting into uncontrolled oscillation, which is in adverse relationship to the speed it can handle. The tendency to oscillate is further aggravated by the load impedance. The load impedance of a system is usually not just a resistor. A cable connected to an amplifier (leading to the receiver or monitor) may present a capacitive and/or an inductive load to the amplifier. This is the main cause for instability. The behavior of a load or cable may severely degrade the performance of the amplifier - its bandwidth, linearity, and stability - and in general its ability to faithfully reproduce the signal.

Cables affect image resolution. Longer cables can cause high frequency deterioration and hence image “smear” and loss of resolution. In computer graphics especially, this adverse effect is very much accentuated. Amplifiers should therefore cope with an additional task - compensating for cable losses up to the maximum useful operation distance. High-resolution graphics systems must use very high quality cables for image transmission. The cables should be shielded to eliminate externally induced interference. However, the shield may increase the capacitance of the cable, and therefore, cause deterioration in the image’s resolution and clarity. Standard cables should only be a few meters long. For longer distances, the compound cable is broken into five individual coax cables, which are bulky and cumbersome for use. Even so, the distance is limited to several tens of meters.

The behavior of a cable may create other problems resulting from the failure to accurately match the system’s required impedance. The result of this, especially at high frequencies, is “shadows” or “ghosts” on the image, resulting from standing waves and electronic reflections running back and forth between transmitter and receiver. Another aspect to consider is the sync. Since the signals are logic signals, which are not treated as analog signals, the receiver does not terminate the line, and therefore the line is not matched. A host of problems might occur when the signals are sent over long, unterminated, unmatched cables. The result might be image breakdown or distortion due to improper sync information. The amplifier that drives the analog section of the graphics data should also be able to buffer, recover and send sync information in such a way that it will be received properly at the receiver end.

### 1.3 Factors Affecting Quality of Results

There are many factors affecting the quality of results when signals are transmitted from a source to an acceptor:

- **Connection cables** - Low quality cables are susceptible to interference; they degrade signal quality due to poor matching and cause elevated noise levels. They should therefore be of the best quality.
- **Sockets and connectors of the sources and acceptors** - So often ignored, they should be of highest quality, since "Zero Ohm" connection resistance is the objective. Sockets and connectors must also match the required impedance (75ohm in video). Cheap, low quality connectors tend to rust, thus causing breaks in the signal path.
- **Amplifying circuitry** - Must have quality performance when the desired end result is high linearity, low distortion and low noise operation.
- **Distance between sources and acceptors** - Plays a major role in the final result. For long distances of over 15 meters (2 to 3meters for VGA/XGA) between sources and acceptors, special measures should be taken in order to avoid cable losses. These include using higher quality cables or adding line amplifiers.
- **Interference from neighboring electrical appliances** - These can have an adverse effect on signal quality. Balanced audio lines are less prone to interference, but unbalanced audio should be installed far from any mains power cables, electric motors, transmitters, etc. even when the cables are shielded.

## 2 SPECIFICATIONS

	VP-31	VP-32xl	VP-61RS
<b>Configuration</b>	3 x 1	3 x (1:2)	6 x 1
<b>Input Type</b>	3 VGA/XGA	3 VGA/XGA, 3 stereo audio, line level	6 VGA/XGA
<b>Input Connections</b>	HD 15F connectors	VGA/XGA: HD 15F connectors Audio: RCA connectors	HD15F connectors
<b>Input Level</b>	0.7Vpp/75ohm, H&V syncs, TTL level	0.7Vpp/75ohm, H&V syncs, TTL level Audio: 1Vpp/50K	0.7Vpp/75ohm, H&V syncs, TTL level
<b>Output Type</b>	1 VGA/XGA	2x1 VGA/XGA 2x1 stereo audio, line level	1 VGA/XGA
<b>Output Connector</b>	HD 15F connector	VGA/XGA: HD 15F connectors Audio: RCA connectors	HD15F connector
<b>Output Level</b>	0.7Vpp/75ohm, H&V syncs, TTL level	0.7Vpp/75ohm, H&V syncs, TTL level Audio: 1Vpp/150 Ohms	0.7Vpp/75ohm, H&V syncs, TTL level
<b>Controls</b>	3 electronic illuminated touch switches with electronic interlock.	3 electronic illuminated touch switches with electronic interlock. Terminal block connector for remote control	6 electronic illuminated touch switches with electronic interlock. RS-232 via an additional DB-9 connector on the back panel.
<b>Output Coupling</b>	Direct transmission by relay	Direct transmission by relay + Active amplification	Direct transmission by relay
<b>Video Bandwidth</b>	Exceeding 450MHz	Exceeding 300MHz	180MHz
<b>Differential Gain</b>	0.05%	0.1%	0.04%
<b>Differential Phase</b>	0.02Deg.	0.06Deg.	0.02Deg.
<b>K-Factor</b>	<0.05%	<0.05%	<0.05%
<b>Non Linearity</b>	<0.05%	0.1%	<0.1%
<b>Video S/N Ratio</b>	73dB	75dB	72.7dB
<b>Audio Bandwidth</b>	NA	100KHz	NA
<b>Audio S/N Ratio</b>	NA	95dB	NA
<b>Audio THD</b>	NA	<0.018%	NA
<b>Max. Audio Level</b>	NA	>5Vpp	NA
<b>Switch Time</b>	<5mS	<5mS	<5mS
<b>Dimensions (W, D, H)</b>	24.5 x 18 x 4.5 (cm) 9.6" x 7" x 1.8"	22 x 18 x 4.5 (cm) 8.7" x 7" x 1.8"	48.3 x 17.8 x 9 (cm) 19" x 7" x 1U
<b>Weight</b>	1.4kg. (3.1lbs.) Approx.	1.1kg. (2.4lbs.) Approx.	2.7kg. (6lbs.) Approx.
<b>Power Consumption</b>	5.1VA	1.8VA	6.2VA
<b>Power Source</b>	230VAC, 50/60 Hz (115VAC, U.S.A.)	12VDC, 150mA	230VAC, 50/60 Hz (115VAC, U.S.A.)

### 3 HOW DO I GET STARTED?

The fastest way to get started is to take your time and do everything right the first time. Taking 15 minutes to read the manual may save you a few hours later. You don't even have to read the whole manual. If a section doesn't apply to you, you don't have to spend your time reading it.

### 4 UNPACKING AND CONTENTS

The items contained in your Kramer switcher package are listed below. Please save the original box and packaging materials for possible future transportation and shipment.

- Switcher
- AC power cable (where applicable)
- User Manual
- KRAMER K-Switch Software for Windows 95/98 downloadable from the Internet (VP-61RS only)
- KRAMER Null Modem Adapter Connector (VP-61RS only)
- Kramer concise product catalog
- 4 rubber feet

#### 4.1 Optional Accessories

The following accessories, which are available from Kramer, can enhance implementation of your switcher. For information regarding cables and additional accessories, contact your Kramer dealer.

- **Rack Adapter** - Used to install smaller size machines in a standard 1U rack. One or more machines may be installed in each adapter.
- **VP-200** - (1:2 High Resolution VGA Distribution Amplifier) can be serially inserted between the switcher and the acceptors. It is a full bandwidth distributor designed for computer and workstations applications. The **VP-200** splits a VGA/Super-VGA/XGA graphics card output to 2 monitors, with no discernible signal degradation. State-of-the-art video amplifying circuitry and microchip technology make the KRAMER **VP-200** the first choice Graphics Component Distributor. Signal bandwidth of 345MHz allows the **VP-200** to be used with the highest quality graphics workstations.
- **VP-300** - (1:3 High Resolution VGA Distribution Amplifier) can be serially inserted between the switcher and the acceptors. It is a full bandwidth distributor designed for computer and workstations applications. The **VP-300** splits a VGA/Super-VGA/XGA graphics card output to 3 monitors, with no discernible signal degradation. State-of-the-art video amplifying circuitry and microchip technology make the KRAMER **VP-300** the first choice Graphics Component Distributor. Signal bandwidth of 345MHz allows the **VP-300** to be used with the highest quality graphics workstations.
- **VP-400** - (1:4 High Resolution VGA Distribution Amplifier) can be serially inserted between the switcher and the acceptors. It is a full bandwidth distributor designed for computer and workstations applications. The **VP-400** splits a VGA/Super-VGA/XGA graphics card output to 4 monitors, with no discernible signal degradation. State-of-the-art video amplifying circuitry and microchip technology make the KRAMER **VP-400** the first choice Graphics Component Distributor. Signal bandwidth of 345MHz allows the **VP-400** to be used with the highest quality graphics workstations.
- **VP-211** - (2x1 Automatic VGA/Audio Switcher) can be serially inserted between the VGA/audio switcher and the acceptors for VGA/audio distribution. It is a full bandwidth switcher designed for computer and presentation applications. The **VP-211** automatically detects the presence of a VGA/XGA signal on input no. 1 and routes it to the output. If the signal disappears, the machine switches to input no. 2 and routes it to the output. When the signal on input no. 1 re-appears, the **VP-211** reroutes input no. 1 to the output. The machine operates in audio-follow-video (VGA) mode and switches the stereo audio input appropriate to the VGA input. Signal bandwidth of 517MHz ensures that the **VP-211** remains transparent even in the most critical applications. The **VP-211** is part of the Kramer TOOLS family of compact, high quality and cost effective solutions for a variety of applications.
- **VP-22** - (VGA / XGA Line Amplifier & Processor) can be serially inserted between the VGA switcher and the acceptors for signal processing. It is a full bandwidth machine designed for computer and workstation applications where remote monitoring is needed. The **VP-22** splits a VGA/Super VGA/XGA graphics card output to 2 remote monitors and allows the user to control signal level and cable equalization for each channel independently. The machine also allows control of horizontal and

vertical sync delay on the BNC coaxial outputs. On its H/HV SYNC output BNC, the **VP-22** allows either horizontal or composite sync while on its green output BNC, it allows either green or green + composite sync. State-of-the-art video amplifying circuitry makes the KRAMER **VP-22** the perfect graphics component amplifier. Signal bandwidth of over 350MHz allows it to be used with the highest quality graphics workstations.

- **VP-101** - (VGA to RGBS Converter) can be serially inserted between the VGA switcher and the acceptors for VGA to RGB conversion. It is a full bandwidth machine designed for computer, workstation and presentation applications. The **VP-101** converts a VGA/Super-VGA/XGA graphics card output to red, green, blue, horizontal/composite sync and vertical sync. The signals are available on BNC connectors. Via a rear panel switch, the **VP-101** allows the user to select either a composite or horizontal sync output. The composite sync generated maintains the correct polarity (negative), at any polarity of Hs and Vs inputs. The input and outputs are AC coupled conforming to the highest standards. The original source bandwidth is retained to well over 300MHz thus allowing the **VP-101** to be used with the highest quality graphics workstations.
  
- **VP-102** - (VGA to RGBS Converter) can be serially inserted between the VGA switcher and the acceptors for VGA to RGB conversion. It is a full bandwidth machine especially designed for computer, workstation and presentation applications. The **VP-102** converts a VGA/Super - VGA/XGA graphics card output to red, green, blue, horizontal/composite sync and vertical sync signals available on BNC connectors. The **VP-102** allows the user to select either a composite or horizontal sync output and the green output either includes composite sync or is blanked. The composite sync generated by the machine is always at the correct polarity (negative), for any polarity of Hs and Vs inputs. As the signal bandwidth is well over 315MHz, the **VP-102** may be used with the highest quality graphics workstations.

## 5 VGA/XGA/AUDIO SWITCHERS

This section describes all the controls and connections of your switcher. Understanding them helps you realize the full power of your switcher.

### 5.1 Getting to Know Your VP-31 Switcher

The KRAMER VP-31 is a full bandwidth, 3x1 VGA/XGA Switcher designed for computer and workstation applications. The VP-31 switches one of three VGA/Super-VGA/XGA graphics card outputs to one monitor or vice versa, with no discernible signal degradation. Input and output are directly coupled and conform to the highest standards. Signal bandwidth of over 450MHz allows the VP-31 to be used with the highest resolution graphics workstations. Front/Rear panel features of the VP-31 are described in Figure 1 and Table 1.

#### NOTE

*For operation instructions refer to section 9.*

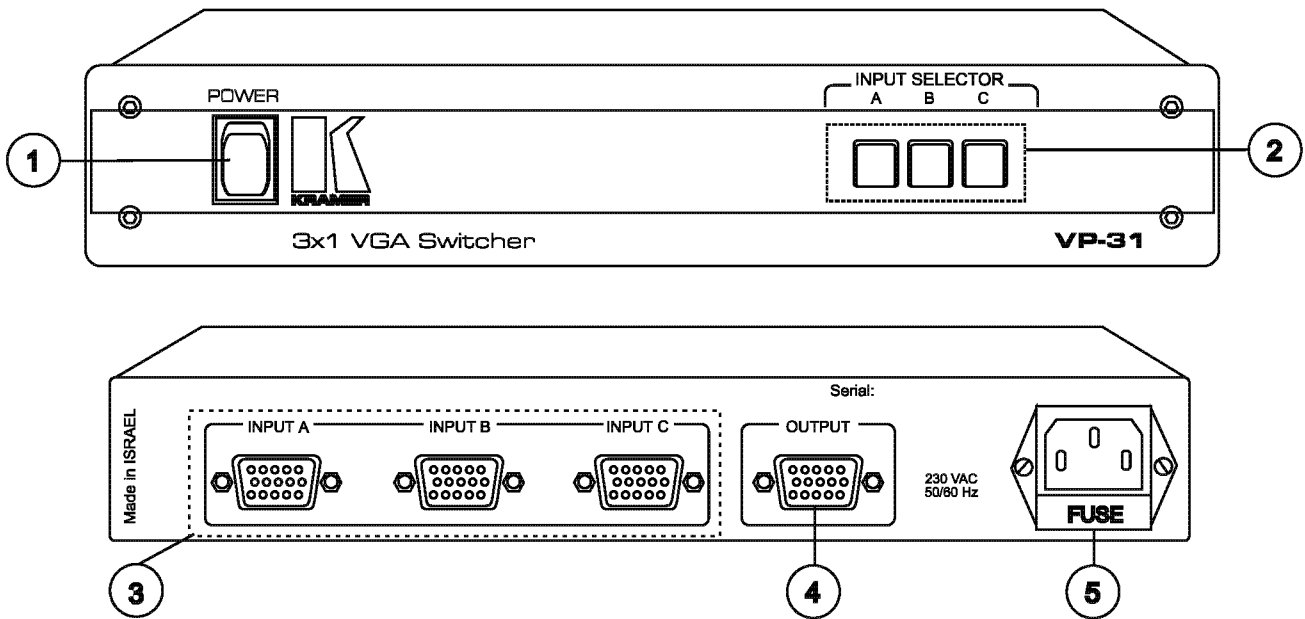

Figure 1: VP-31 Front/Rear Panel Features

Table 1: VP-31 Front/Rear Panel Features

No.	Feature	Function
1.	Illuminated power switch	Supplies power to the unit.
2.	<b>INPUT SELECTOR</b> switches (A, B, C)	Select the desired input to be switched to the output.
3.	<b>INPUT (A-C)</b> HD 15F Connectors	VGA/XGA video input
4.	<b>OUTPUT</b> HD 15F Connector	VGA/XGA output.
5.	Power connector	A 3-prong AC connector allows power to be supplied to the unit. Directly underneath this connector, a fuse holder houses the appropriate fuse.



## 5.2 Getting to Know Your VP-32xl Switcher

The KRAMER **VP-32xl** is a full bandwidth, 3x1 VGA/Audio Stereo Switcher designed for computer, workstation and presentation applications. The **VP-32xl** switches one of three sets of VGA/Super-VGA/XGA graphics/Audio stereo sources into up to two monitors or wide screen projectors, with no discernible signal degradation. Output of the **VP-32xl** is divided into two, thus it functions as a VGA/Audio DA as well. The **VP-32xl** uses a 12Volt DC power source and is therefore perfectly suitable for fieldwork. VGA bandwidth of 300 MHz allows the **VP-32xl** to be used with the highest resolution graphics workstations.

Front/Rear panel features of the VP-32xl are described in Figure 2 and Table 2.

### NOTE

*For operation instructions refer to section 9.*

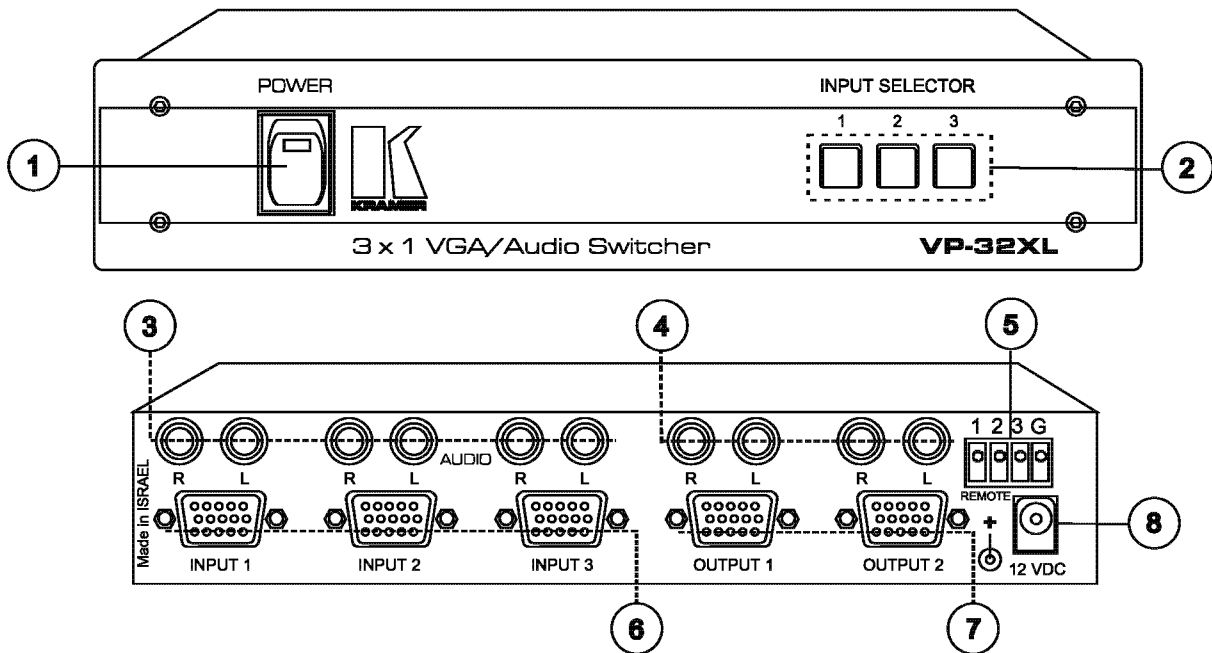

**Figure 2: VP-32xl Front/Rear Panel Features**

**Table 2: VP-32xl Front/Rear Panel Features**

No.	Feature	Function
1.	Illuminated power switch	Supplies power to the unit.
2.	<b>INPUT SELECTOR</b> switches (A, B, C)	Select the desired input to be switched to the output.
3.	<b>R, L</b> RCA connectors (1-3)	Audio input.
4.	<b>R, L</b> RCA connectors (1-2)	Amplified and buffered audio outputs.
5.	Terminal block <b>REMOTE</b> connector	Used for manual remote control
6.	<b>INPUT (1-3)</b> HD 15F Connectors	VGA/XGA video input
7.	<b>OUTPUT</b> HD 15F Connector	Amplified and buffered VGA/XGA output.
8.	<b>12VDC</b> Power Connector	A DC connector that allows power to be supplied to the unit.

### 5.3 Getting to Know Your VP-61RS Switcher

The KRAMER **VP-61RS** is a full bandwidth, 6x1 VGA/XGA Switcher designed for computer and workstation applications. The **VP-61RS** switches one of six VGA/Super-VGA/XGA graphics card outputs to one monitor or vice versa, with no discernible signal degradation. The **VP-61RS** also has RS-232 control. Input and output are directly coupled and conform to the highest standards. Signal bandwidth of over 180MHz allows the **VP-61RS** to be used with the highest resolution graphics workstations. Front/Rear panel features of the VP-61RS are described in Figure 3 and Table 3.

**NOTE**

*For operation instructions refer to section 9.*

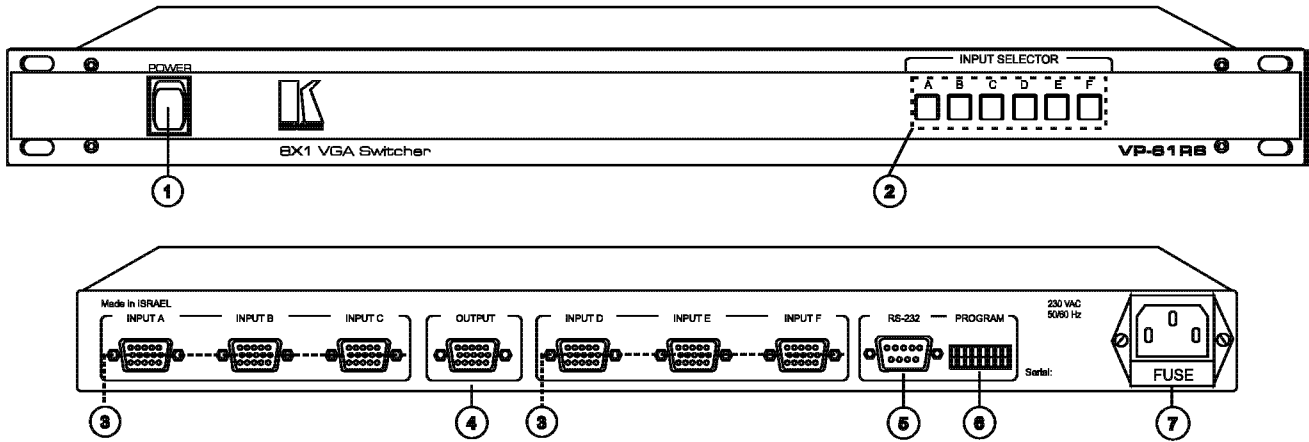

**Figure 3: VP-61RS Front/Rear Panel Features**

**Table 3: VP-61RS Front/Rear Panel Features**

No.	Feature	Function
1.	Illuminated power switch	Supplies power to the unit.
2.	<b>INPUT SELECTOR</b> switches (A-F)	Select the desired input to be switched to the output.
3.	<b>INPUT A-F</b> HD 15F connectors	6 VGA/XGA inputs.
4.	<b>OUTPUT</b> HD 15F Connector	VGA/XGA output.
5.	<b>RS-232</b> HD 15F Connector (DB-9 female connector)	Used for control of the switcher from a PC through an RS-232 interface.
6.	<b>PROGRAM</b> Dip Switches	Allow proper configuration of the control signals received and transmitted through the RS-232 control port, master/slave configurations, and device ID numbers.
7.	Power connector	A 3-prong AC connector allows power to be supplied to the unit. Directly underneath this connector, a fuse holder houses the appropriate fuse.

## 6 INSTALLATION

### 6.1 Rack Mounting

The VP-61RS switcher described in this manual includes rack “ears” at the ends of the front panel and may be rack mounted in a standard 19” (1U) EIA rack assembly. The VP-31 and the VP-32*x/l* can also be installed in a rack, using a special rack adapter (contact your KRAMER dealer). These machines do not require any specific spacing above or below the unit for ventilation. To mount any of the switchers, simply place the rack ears against the rails of your rack, and insert standard screws through each of the four corner holes in the rack ears.

## 7 CONNECTING TO VGA/XGA DEVICES

Video sources and output devices (such as monitors, projectors or recorders) may be connected to the switchers through the HD 15F connectors located on the back of the unit. Unused inputs are terminated to 75ohm, and active inputs should be terminated by the connecting source.

## 8 CONNECTING TO AUDIO DEVICES

Audio sources and output devices may be connected to the switchers (VP-32*x/l* only) through the RCA type connectors located on the back of the unit.

## 9 USING THE SWITCHERS

### 9.1 Powering on the Switcher

#### NOTES

*Switcher should only be powered on after all connections are complete, and all source devices have been powered on. Do not attempt to connect or disconnect any video, audio or control signals to the switcher while it is powered on!*

*The socket-outlet should be near the equipment and should be easily accessible. To fully disconnect equipment, remove power cord from its socket after it has been turned off.*

- 1) Press the toggle switch on the far-left front panel to the up position. In the up position, the toggle switch glows and the active input button illuminates as well.
- 2) Operate the acceptors.

### 9.2 Selecting an Input on the Switchers

Input selection on the switchers described in this manual is simply made by pressing buttons marked “1”, “2” etc. or “A”, “B”, “C”, etc. on the front panel, or by operating via your preferred remote device (see section 9.3). These buttons correspond to the input connections as marked on the back panel.

### 9.3 Controlling the VP-32*x/l*

The VP-32*x/l* switcher can be controlled by the following methods:

- 1) By touch buttons on the front panel (see section 9.2 "Selecting an Input on the Switchers").
- 2) By direct remote contact closure via the terminal block connector (e.g. a switch panel that the user rigs up).

To remote control the VP-32*x/l*, wire the Remote Connector as shown in Figure 4. Grounding one of the inputs 1-3 selects the active input to be switched to both outputs "1" & "2".

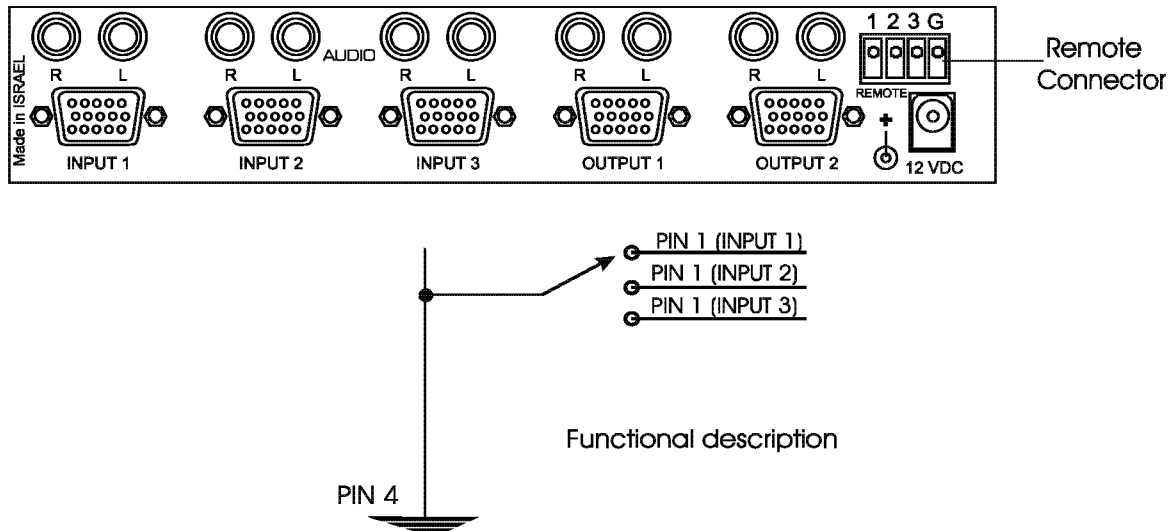

Figure 4: VP-32x/ Remote Connector Location and Pinout

## 9.4 Controlling the VP-61RS

The VP-61RS switcher can be controlled by the following methods:

- 1) By touch buttons on the front panel (see section 9.2 "Selecting an Input on the Switchers").
- 2) By any RS-232 controller such as a PC or the VS-2000 (for more information, refer to Section 9.4.1: "The VS-2000 System") which is programmed according to the protocol of the switcher (see Section 13: "Protocol Used for VP-61RS Communication").

### 9.4.1 The VS-2000 System

The KRAMER VS-2000 is a Programmable Remote Control Unit, designed for use in video production and duplication studios and in live broadcasting and editing configurations. It provides access to and control of up to six groups of KRAMER switchers from a single point. A group can comprise several interconnected switchers which, in turn, permit access to various pieces of equipment (monitors, mixers, editors, VCRs, etc). The VS-2000 can be controlled by pressing its front panel touch buttons, and via a PC using the RS-232 control port. KRAMER PC control software is provided with the VS-2000. Since new switcher types are constantly being added and older types upgraded, KRAMER provides a small door marked "EPROM" on the VS-2000 rear panel for easy replacement of the existing chip with an updated one which contains appropriate information for new and modified switchers. KRAMER makes updated chips available periodically. The VS-2000 stores and recalls preferred configurations for convenience in studio control. A typical VS-2000 system setup using the VP-61RS is shown in Figure 5. To connect and operate the VS-2000 System perform the following steps (for more details about the VS-2000 refer to the instruction manual provided with the VS-2000).

- 1) Connect up to six switchers via RS-232 ports on each machine to the connectors on the rear panel of the VS-2000 marked "Port 1" to "Port 6" using straight DB9 to DB9 male to male flat cable.
- 2) Connect a PC equipped with a serial port to the socket marked "TO PC" on the rear panel of the VS-2000, using the null modem adapter provided with the machine. Use a straight DB9 to DB9 connector if you are using the null modem adapter, or connect as in Figure 7.
- 3) Connect a 12VDC power supply to the 12VDC socket on the rear panel of the VS-2000. Use a DC wall transformer with a positive center pin.
- 4) Turn on all the machines and the VS-2000.
- 5) To install the software provided for PC control, copy it into a sub directory on your hard disk and read the **BC-2000.HLP** file. You can print it for later reference. The file name **BC20PROT.HLP** is the communication protocol for advanced users.

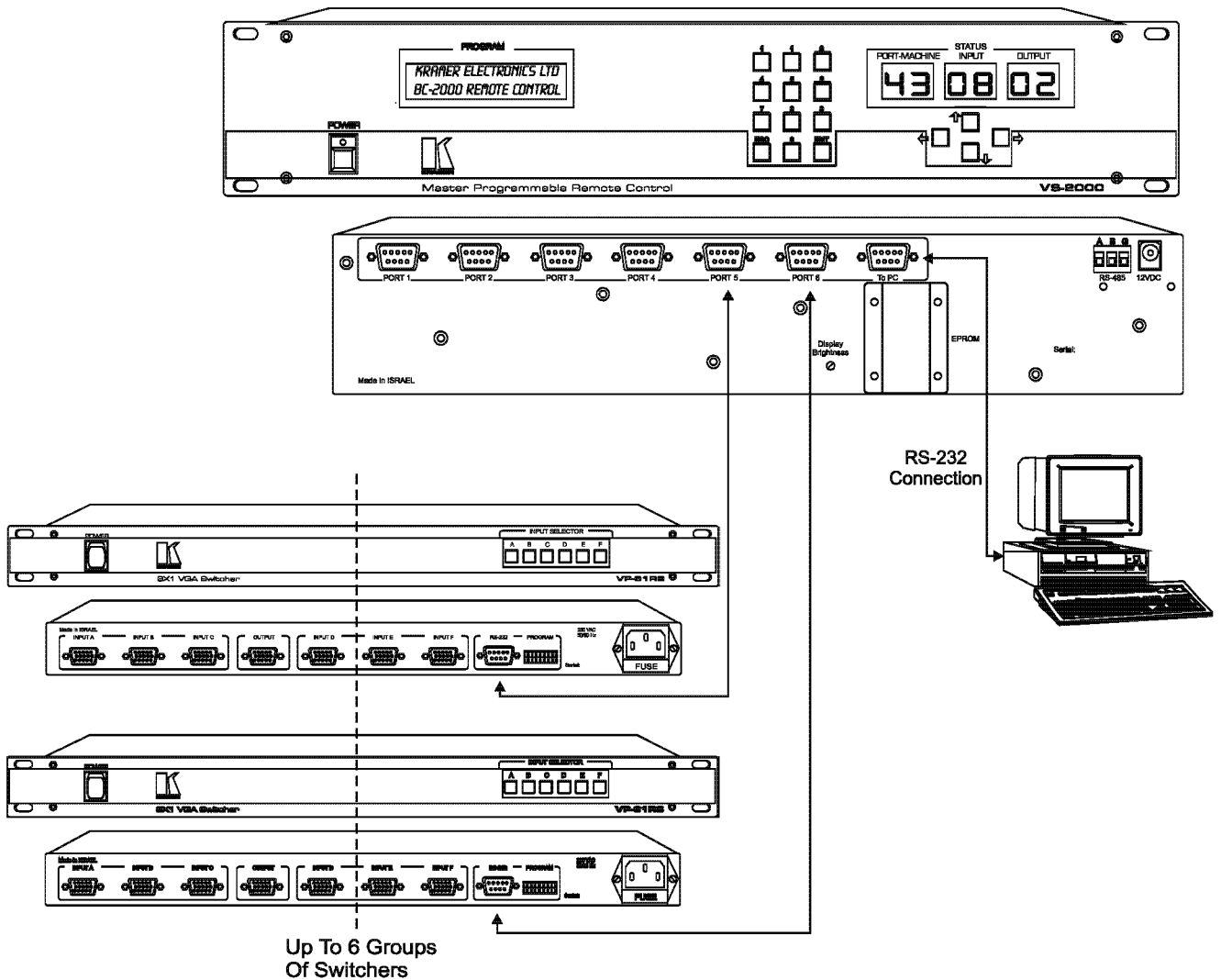

Figure 5: Typical VS-2000 System Setup

#### 9.4.2 DIP Switches

The VP-61RS selects one of up to 6 VGA/Super-VGA/XGA standard signals. As indicated above, there are two options for operating the switcher, both available without removing the switcher cover: by touching one of the front panel switches or by a remote PC via the RS-232 connectors on its rear panel.

When the switcher is operated via the RS-232 connector or when it is interconnected with other switchers, the DIP switch (see Table 4) on the rear panel allows proper configuration of the control signals received/transmitted through the RS-232 control port. The VP-61RS allows master/slave configurations so that the switchers may operate independently, or in conjunction with each other.

**Table 4: DIP Switch Settings**

Machine #	PROGRAM				ADDRESS			
	1	2	3	4	5	6	7	8
1 (Master)	ON	OFF	ON	ON	OFF	OFF	OFF	OFF
2 (Slave)	OFF	OFF	OFF	ON	OFF	OFF	OFF	ON
3 (Slave)	OFF	OFF	OFF	ON	OFF	OFF	ON	OFF
4 (Slave)	OFF	OFF	OFF	ON	OFF	OFF	ON	ON
5 (Slave)	OFF	OFF	OFF	ON	OFF	ON	OFF	OFF
6 (Slave)	OFF	OFF	OFF	ON	OFF	ON	OFF	ON
7 (Slave)	OFF	OFF	OFF	ON	OFF	ON	ON	OFF
8 (Slave)	OFF	OFF	OFF	ON	OFF	ON	ON	ON

**Legend:**

- Switches 1, 2, 3: RS232
- Switch 4: Reply
- Switch 5: Baud Rate (Off=1200, On=9600 Baud)
- Switches 6, 7, 8: ADDRESS

**9.4.3 The "Reply" Option**

When the PC addresses the Master/Slave machines, a "Reply" signal is sent back to the PC indicating that the addressed machine received the instruction. When several machines are connected in parallel (all with the same machine number), it is not allowed for all of them to transmit at the same time so only the Master machine replies (switch 4 is enabled).

**NOTE**

*The Slave "Reply" settings are all ON or all OFF, depending on the requirements of the system. The Master "Reply" setting is always ON.*

**9.5 VGA/XGA Switching**

Computer based graphics is used in video production, in presentation applications, for education purposes and more. In many cases it is necessary to switch PC graphics from several sources to one or more acceptors. Figure 6 describes a typical VGA/XGA (VP-61RS) switching set-up, where six different input sources are switched to one acceptor. To construct this set-up, perform the following steps:

- 1) Connect all component sources to the appropriate inputs of the switcher.
- 2) Connect XGA/VGA acceptor/s to the output/s of the switcher.
- 3) Connect PC or controlling unit.
- 4) Operate the switcher, sources and acceptors.
- 5) Select the required input to be switched, using front panel input selector pushbuttons.

**Some useful tips:**

- ◆ Always keep distances between sources and acceptors as short as possible.
- ◆ Keep all cable lengths identical, as final quality may be severely degraded if cables carrying different components are of unequal lengths.
- ◆ Use best possible quality cables for interconnection. Component video signals carry high frequency information which deteriorates rapidly when using low quality cables.

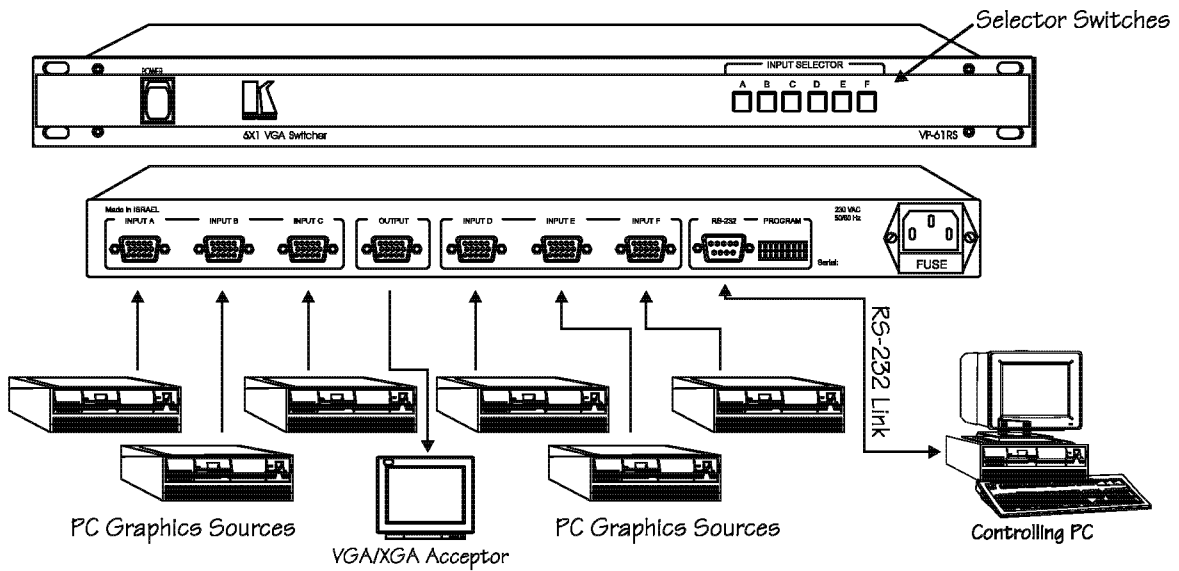

Figure 6: Typical VGA/XGA Switching

## 10 CONNECTING TO A PC (VP-61RS only)

To connect directly to a PC without using the KRAMER Null-Modem Adapter, make connections as in Figure 7. To use the KRAMER Adapter instead (recommended), plug one end into the PC's serial port, then connect from the other end to the switcher using a 9-pin flat-cable. When several machines are to be connected together, make the connections as in Figure 8, or extend pins "5" and "9" only.

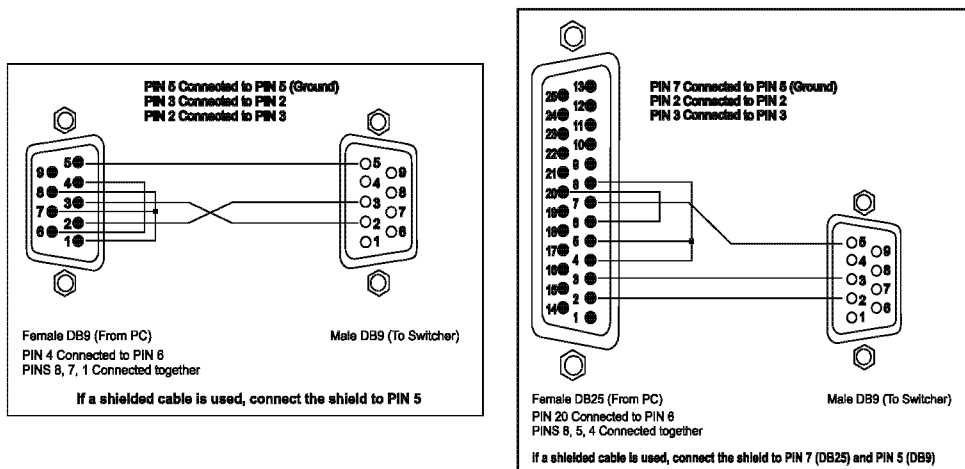

Figure 7: RS-232 Control Connector Wiring

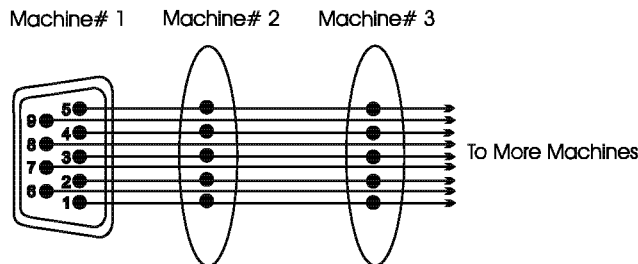

Figure 8: Connecting Multi-Machines

## 10.1 PC Control Software

### 10.1.1 Installation

To install the Control software perform the following steps:

- 1) Download the software from the Internet ([www.kramerelectronics.com](http://www.kramerelectronics.com), technical support section, K\_switch folder and follow instructions.) Insert diskette #1 into the floppy drive of your PC.
- 2) From within Windows 95/98® run Setup.exe on the first diskette and follow the instructions. The **K-Switch** software and icon are automatically installed in a specific destination folder on the hard disk.
- 3) Once the installation is complete, the **K-Switch** program may be run.

### 10.1.2 Software Controls

The software controls are described below:

◆ **Machine Number** (where applicable)

The number of the machine in a group of chained switchers, where each machine can be addressed individually using this option. Note that machine number "1" is always the Master.

◆ **Input Selector** buttons

Select the input which will be connected to the output. The input button default color is yellow and it turns red when connected (clicked).

◆ **Save** button

When clicked, saves the current configuration of all the chained switchers: To save configuration: click on **Save** and then click on the desired **Setup Window Number**. Note that after clicking **Save**, the selected button blinks in red when occupied and in green when free.

**NOTE**

*Canceling Save/Recall functions and deactivating Setup Window Number can be done by clicking Save/Recall buttons again or by clicking the right button of the mouse.*

◆ **Recall** button

When clicked recalls and displays on the screen a saved configuration of chained switchers. To recall a configuration, click on the **Recall** button and then select the desired **Setup Window Number**.

◆ **Switcher** button

When clicked, selects a switcher model.

◆ **Port** button

Defines the active serial port (**COM1-COM4**) to which the switcher/matrix is connected. To select a port, click on the **Port** button. When the **Port** screen appears, select the desired port and click **Ok**. Switching a number from 1-4 followed by clicking the **Save** button, changes the active port number.

◆ **Restart** button

Displays the current configuration of the connected switcher on the screen.

◆ **Help** button

When clicked, a **Kramer Switchers Help** screen appears allowing you to view either the Communication protocol (by clicking the **Communication protocol** button), or the current software version (by clicking **About**). Click **Ok** after the selection is complete.

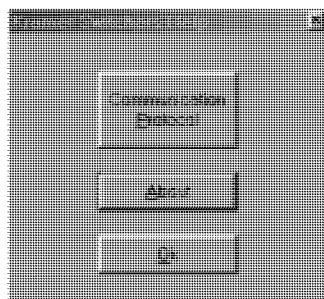

◆ **Exit** button

When clicked, allows you to exit the program. You are prompted to confirm that you want to exit.





- 6) The **Main Menu** (with the switcher model number on top) appears.

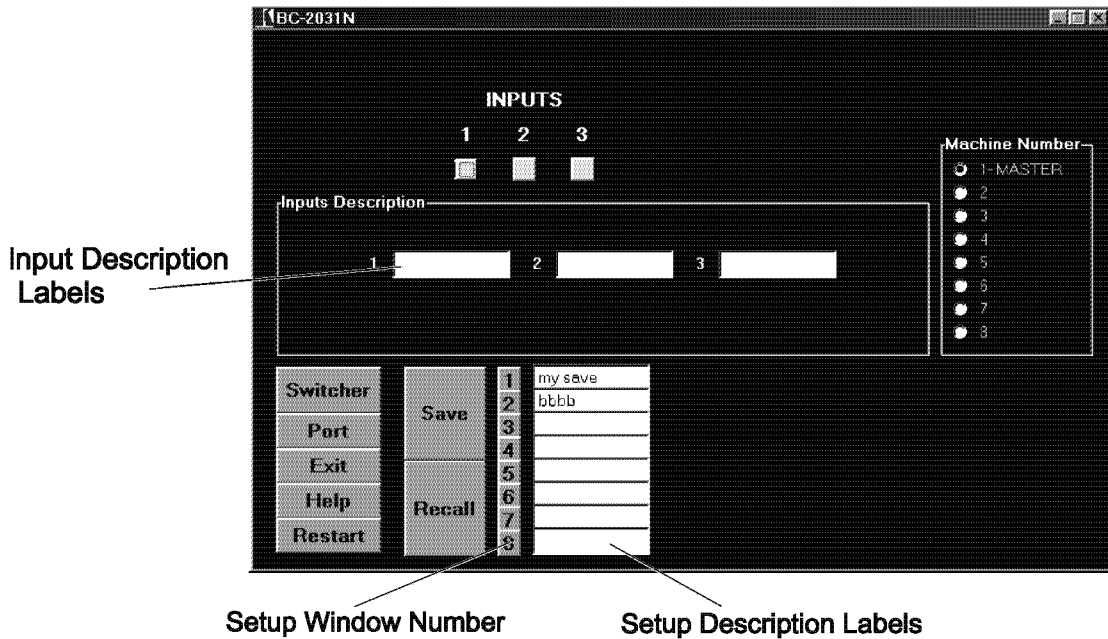

- 7) If properly connected and with the right COM port selected, you can identify your switcher and view an image representing its control panel on the PC monitor (with the current configuration).  
 8) If the COM or switcher is not properly selected, "**Communication Error**" message appears.



- 9) To exit the program, click the "**Exit**" button. You are prompted for confirmation.

**NOTE**

*When clicking "Exit", the program automatically stores the active port number and your switcher ID. When the program is run again, this port and switcher ID automatically appear.*

## 11 TAKING CARE OF YOUR SWITCHER

Do not locate your switcher in an environment where it is susceptible to dust or moisture. Both of these may damage the electronics, and cause erratic operation or failure. Do not locate your switcher where temperature and humidity may be excessive. Doing so may also damage the electronics, and cause erratic operation or failure of your switcher. Do not clean your switcher with abrasives or strong cleaners. Doing so may remove or damage the finish, or may allow moisture to build up. Take care not to allow dust or particles to build up inside unused or open connectors.

## 12 TROUBLESHOOTING

### NOTES

1. Please note that if the output signal is disturbed or interrupted by very strong external electromagnetic interference, it should return and stabilize when such interference ends. If not, turn the power switch off and then on again to reset the machine.
2. If the following recommended actions still do not result in satisfactory operation, please consult your KRAMER Dealer.

### 12.1 Power and Indicators

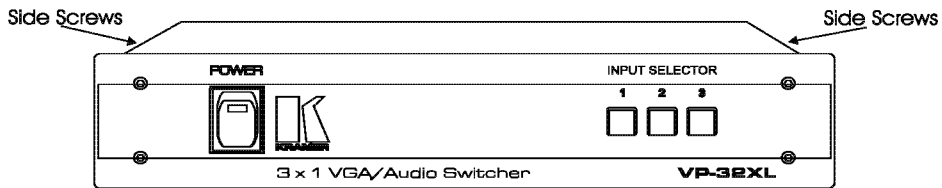
Problem	Remedy
No Power	<ol style="list-style-type: none"> <li>1. Confirm that rocker switch is in “ON” position, and LED is illuminated.</li> <li>2. Confirm that power connections are secured at the switcher and at the receptacle. Make sure the receptacle is active, outputting the appropriate voltage.               <ul style="list-style-type: none"> <li>➤ <b>For the VP-31 and the VP-61RS models perform the following:</b> <ol style="list-style-type: none"> <li>1. If still there is no power, remove power cord from AC outlet and then using a flat head screwdriver, remove the fuse holder located directly below the power connector on your switcher.</li> <li>2. Confirm that the fuse is good by looking for the wire connected between the ends of the fuse. If the wire is broken, replace fuse the with another, with the same rating.</li> </ol> </li> <li>➤ <b>For the VP-32xl perform the following:</b> <ol style="list-style-type: none"> <li>1. Using a Philips screwdriver, remove 4 side screws attaching the machine's cover.                   <div data-bbox="491 1133 1437 1319" data-label="Image">  </div> </li> <li>2. Remove 2 screws and 3 brackets tightening the audio board to the video board and remove board.</li> <li>3. Locate the fuse holder located inside your switcher (see Figure 9). Confirm that the fuse is good by looking for the wire connected between the ends of the fuse. If this wire is broken, replace the fuse with another, with the same rating.</li> <li>4. Tighten 2 screws and 3 brackets of the audio board.</li> <li>5. Replace the machine cover and its screws.</li> </ol> </li> </ul> </li> </ol>

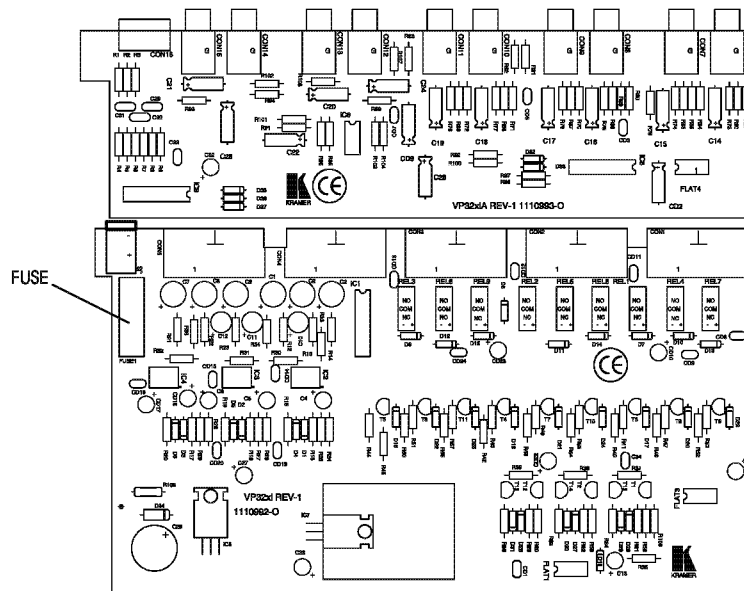

**Figure 9: VP-32x/ Fuse Location**

## 12.2 Audio Signal (VP-32x/ only)

Problem	Remedy
No audio at the output device, regardless of input selected	<ol style="list-style-type: none"> <li>1. Confirm that your sources and output device are powered on and connected properly. Audio signals connected to the input of your switcher should be properly wired to the output of your source. Audio signals connected to the output of your switcher should be properly wired to the input of your line amplifier or recorder.</li> <li>2. Confirm that any other amplifiers in the signal path have the proper input and/or output selected. Pay special attention to input amplifiers that may be built into your acceptor.</li> </ol>
Audio level is too low	<ol style="list-style-type: none"> <li>1. Confirm that the connecting cables are of high quality and properly built.</li> <li>2. Check level controls located on your source input device or output display or recorder.</li> </ol>

## 12.3 VGA/XGA Signal

Problem	Remedy
No signal at the output device, regardless of input selected.	<ol style="list-style-type: none"> <li>1. Confirm that your sources and output device are powered on and connected properly.</li> <li>2. Confirm that any other switchers in the signal path have the proper input and/or output selected.</li> </ol>
Signal level is too high or too dim.	<ol style="list-style-type: none"> <li>1. Verify that the VGA/XGA line is well matched through 75ohm impedance.</li> <li>2. Confirm that the connecting cables are of high quality and properly built. Check level controls (if available) located on your source input device or output display.</li> </ol>

Problem	Remedy
<p>Noise bars are "rolling" up or down in the output VGA/XGA image</p> <p>or:</p> <p>Low Frequency Hum in the output audio signal</p>	<p>Hum bars (ground loop) are caused by a difference in the ground potential of any two or more devices connected to your signal path. This difference is compensated by passing that voltage difference through any available interconnection, including your VGA/XGA cables.</p> <p style="text-align: center;"><b>WARNING!</b></p> <p style="text-align: center;"><i><b>DO NOT DISCONNECT THE GROUND FROM ANY PIECE OF VGA/XGA/AUDIO EQUIPMENT IN YOUR SIGNAL PATH!</b></i></p> <p>Check the following to remove hum bars:</p> <ol style="list-style-type: none"> <li>1. Confirm that all interconnected equipment is connected to the same phase of power, if possible.</li> <li>2. Remove equipment connected to that phase that may introduce noise, such as motors, generators, etc.</li> </ol>

#### 12.4 Control (VP-61RS only)

Problem	Remedy
<p>No control of switcher from VS-2000 control panel</p>	<ol style="list-style-type: none"> <li>1. Confirm that the connecting cable is wired for pins 1-9 straight through.</li> <li>2. Confirm that all DIP switches on the switcher have been set properly. Keep in mind that if you are controlling only one switcher on a specific port, that switcher must be assigned the ID of "1".</li> <li>3. If controlling more than one switcher on a single port, all switchers must be of the same type and power to all switchers must be on.</li> <li>4. Confirm that you have the proper machine number and control port selected on the VS-2000. For instance, if you are controlling a single machine on port 1, then both of these should be set to "1".</li> <li>5. Confirm that you have the proper switcher type selected on the VS-2000. If not, go back to Section 9.4.1 of this manual "The VS-2000 System".</li> </ol>
<p>No control of switcher from the PC software</p>	<ol style="list-style-type: none"> <li>1. Confirm the wiring of the connecting cable. This pin configuration may be found in Section 10 "CONNECTING TO A PC". Cable length should not exceed 25 feet.</li> <li>2. Confirm that all DIPswitches on the switcher have been set properly. Keep in mind that if you are only controlling one switcher on a specific port, that switcher must be assigned the ID of "1".</li> <li>3. If controlling more than one switcher on a single port, all switchers must be of the same type and power to all switchers must be on.</li> <li>4. Confirm that the baud rate of your computer COM port is set to the same as that of your switcher (e.g. 9600-Baud). Confirm that the proper COM port is selected in the control software.</li> <li>5. With custom software, do not send multiple commands at the same time. Wait for the switcher to reply to a command before sending the next command.</li> <li>6. Confirm that the computer you are using supports true RS-232C protocol. Computers such as the Apple Macintosh do not!</li> </ol>

## 13 PROTOCOL USED FOR THE VP-61RS COMMUNICATION

The protocol used for communication between the PC and the VP-61RS is defined below. The rate of data is 9600 baud with no parity, 8 data bits and one stop bit. To work at 1200 baud, DIP switch number 5 should be set to "OFF".

N7	N6	N5	N4	N3	N2	N1	N0
MSB							LSB

### 13.1 Detailed Description

N7	Used for communication between the Slave and the Master only and is always "0" for communication with the PC
N6N5N4	is the binary value of the machine we are addressing minus one, e.g., if we wish to address the Master (machine 1 by definition), then $N6N5N4 = 000$ , if we wish to address machine 6, then $N6N5N4 = 101$ .
N3N2N1N0	is the binary value of the input to be selected, i.e. $N3N2N1N0 = 0110$ is equivalent to pressing switch No. 6 of the machine.

Several special codes are also valid:

N3N2N1N0	1101 requests that the Machine being addressed sends its present status to the PC, i.e. which input is selected on its front panel.
N3N2N1N0	1110 is an "OK" handshake, i.e. confirmation that the instruction was received by the addressed Machine. (If the addressed machine is not present, then this confirmation is not sent to the PC).

Information sent from the Master to the PC is done using the same format:

<b>0</b>	<b>Machine number-1</b>	<b>New switch status</b>
N7	N6N5N4	N3N2N1N0

## **LIMITED WARRANTY**

Kramer Electronics (hereafter Kramer) warrants this product to be free from defects in material and workmanship under the following terms.

### **HOW LONG IS THE WARRANTY**

Labor and parts are warranted for three years from the date of the first customer purchase.

### **WHO IS PROTECTED**

Only the first purchase customer may enforce this warranty.

### **WHAT IS COVERED AND WHAT IS NOT COVERED**

Except as below, this warranty covers all defects in material or workmanship in this product. The following are not covered by the warranty:

- 1) Any product which is not distributed by Kramer or which is not purchased from an authorized Kramer dealer. If you are uncertain as to whether a dealer is authorized, please contact Kramer at one of the agents listed in the web site [www.kramerelectronics.com](http://www.kramerelectronics.com).
- 2) Any product, on which the serial number has been defaced, modified or removed.
- 3) Damage, deterioration or malfunction resulting from:
  - a) Accident, misuse, abuse, neglect, fire, water, lightning or other acts of nature.
  - b) Product modification, or failure to follow instructions supplied with the product.
  - c) Repair or attempted repair by anyone not authorized by Kramer.
  - d) Any shipment of the product (claims must be presented to the carrier).
  - e) Removal or installation of the product.
  - f) Any other cause, which does not relate to a product defect.
  - g) Cartons, equipment enclosures, cables or accessories used in conjunction with the product.

### **WHAT WE WILL PAY FOR AND WHAT WE WILL NOT PAY FOR**

We will pay labor and material expenses for covered items. We will not pay for the following:

- 1) Removal or installations charges.
- 2) Costs of initial technical adjustments (set-up), including adjustment of user controls or programming. These costs are the responsibility of the Kramer dealer from whom the product was purchased.
- 3) Shipping charges.

### **HOW YOU CAN GET WARRANTY SERVICE**

- 1) To obtain service on you product, you must take or ship it prepaid to any authorized Kramer service center.
- 2) Whenever warranty service is required, the original dated invoice (or a copy) must be presented as proof of warranty coverage, and should be included in any shipment of the product. Please also include in any mailing a contact name, company, address, and a description of the problem(s).
- 3) For the name of the nearest Kramer authorized service center, consult your authorized dealer.

## LIMITATION OF IMPLIED WARRANTIES

All implied warranties, including warranties of merchantability and fitness for a particular purpose, are limited in duration to the length of this warranty.

## EXCLUSION OF DAMAGES

Kramer's liability for any defective products is limited to the repair or replacement of the product at our option. Kramer shall not be liable for:

- 1) Damage to other property caused by defects in this product, damages based upon inconvenience, loss of use of the product, loss of time, commercial loss; or
- 2) Any other damages, whether incidental, consequential or otherwise. Some countries may not allow limitations on how long an implied warranty lasts and/or do not allow the exclusion or limitation of incidental or consequential damages, so the above limitations and exclusions may not apply to you.

This warranty gives you specific legal rights, and you may also have other rights, which vary from place to place.

**NOTE:** All products returned to Kramer for service must have prior approval. This may be obtained from your dealer.

---

## NOTICE

This equipment has been tested to determine compliance with the requirements of:

- EN-50081:** "Electromagnetic compatibility (EMC);  
generic emission standard.  
Part 1: Residential, commercial and light industry"
- EN-50082:** "Electromagnetic compatibility (EMC) generic immunity standard. Part 1:  
Residential, commercial and light industry environment".
- CFR-47** FCC Rules and Regulations:  
Part 15- "Radio frequency devices:  
Subpart B- Unintentional radiators

## CAUTION

- Any user who makes changes or modifications to the unit without the express approval of the manufacturer will void user authority to operate the equipment.
- Servicing should be done only by qualified technicians, approved by Kramer Electronics Ltd.
- Use the supplied AC power cord to supply power to the switcher and controllers.
- Please use recommended interconnect cables to connect the switcher to controllers and other components.

---

## KRAMER ELECTRONICS, LTD.



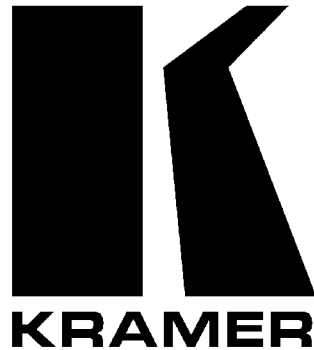

**The list of Kramer distributors appears on our web site:**

**[www.kramerelectronics.com](http://www.kramerelectronics.com)**

**From the web site it is also possible to e-mail factory headquarters.**

**We welcome your questions, comments and feedback.**

---

**KRAMER ELECTRONICS, LTD.**

3 Am VeOlamo Street. Jerusalem 95463, Israel Tel: (972-2)-654-4000. Fax: (972-2)-653-5369  
e-mail: [kramere@netvision.net.il](mailto:kramere@netvision.net.il)